



Edition

11/2025

TECHNICAL HANDBOOK

MOBILE 40kW

HE9818004-.. / 8EM2000-.....-.....

SIEMENS

Mobile 40kW

Technical Handbook

Technical Handbook overview	1
Introduction	2
Safety	3
Logistics	4
Technical	5
Product	6
Instruction for use	7
Maintenance	8
Troubleshooting	9

Preface

Siemens designs, builds and manufactures world class rapid charging solutions that are tailored and scalable within a fast changing e-mobility landscape. We are working towards a sustainable world where a seamless charging experience is the standard for every electric vehicle, and this transforms the way we power our everyday.

This technical handbook covers the Mobile 40kW and provides all the information required for safe operation and maintenance of this equipment.

The Mobile 40kW consists of a power unit (PU), a user interface and is mounted on a mobile frame. With these options Mobile 40kW provides a complete charging system or Electric Vehicle Supply Equipment (EVSE).



Figure 1: Mobile 40kW

Feedback

Siemens appreciates all feedback and suggestions for improvement. If you have any questions or notice any errors in the Technical Handbook, please contact Siemens at the following address:

E-mail: technical.writing.si@siemens.com

Web address: <https://www.siemens.com/de/de/produkte/energie/emobility.html>

Siemens

Siemens refers to Siemens eMobility Charging B.V. or its subsidiaries, collectively and individually hereinafter referred to as "Siemens".

Disclaimer

By accessing and using information, data and materials or related graphics contained in this document, the user hereby agrees to accept the following: Siemens provides no warranty or representation regarding accuracy, completeness or reliability in this document. All information, data, materials, and graphics are subject to modification without prior notice. While we strive for accuracy, Siemens assumes no obligation to update any content contained herein. This document is made available by Siemens for informational purposes only and no action should be taken without first viewing the official records and regulations adopted by Siemens. To the maximum extent permitted by law, Siemens disclaims all liability arising from the use of, or inability to use, the information contained in this document. Users assume the entire risk associated with the use of any information obtained from this document. By using this document, you expressly waive any claims for damages, costs, or expenses that may arise from your reliance on the information provided, regardless of whether Siemens has been advised of the possibility of such damages. This document is originally written in English language, which is the official version of the document. Therefore, documents in other languages are translations of the original document and in the event of any conflict between any translation of the documents, the English version shall prevail.

Copyright

© Copyright 2025 Siemens. All rights reserved. Siemens has the right to revise this document from time to time without prior notification. The information in this document is property of Siemens. No part of this document may be reproduced, stored in a retrieval system, or transmitted in any form or by any means electronic or mechanical, including photocopying and recording for any purpose without the express written permission from Siemens.

Trademarks

The copyright of the (registered) trademarks are the property of Siemens or the respective owners.

Document management

This Technical Handbook is an integral part of the Mobile 40kW. It is the responsibility of the copy holder to use the latest versions of the Technical Handbook and related appendices.

It is possible that a service bulletin may be issued to provide important safety information. These service bulletins form an integral part of the Technical Handbook.

If changes occur, a new copy will be distributed, and the copy holder shall take care of a controlled distribution and the disposal of the previous copy.

Date dd/mmm/yyyy	Version	Document manager	Description
26-Mar-2025	2.0	PS	New Template and Updated.
9-Jul-2025	2.1	JS	Added Directiv 2012/19/EU information as section 5.6.3. End of Life.
13-Aug-2025	2.2	JS	- Updated Preface: Mobile 40kW is mounted on a mobile frame. Updated cross-references in section 3.12.1 Make the System Safe.
15-Aug-2025	2.3	JS	Updated cross-reference in section 3.9.1. Lifting and Hoisting Safety.
18-Nov-2025	3.0	JS & PS	General revision including update to Siemens branding, product naming conventions and article code structure. First release. Incorporated feedback.
21-Nov-2025	3.1	JS	Final review comments implemented.

Abbreviations and terminology

Abbreviation	Definition / Description
AC	Alternating Current
ACB	Auxiliary Circuit Breaker
ACD	Automated Coupler Device
API	Application Programming Interface
CAN	Controller Area Network
CaaS	Charge as a Service
CCS	Combined Charging System
CE	Conformité Européenne (European Conformity)
CMS	Cable management system
CP	Control Pilot
DC	Direct Current
DCC	Demand Connection Code
DSO	Distribution System Owner
EMI	Electro Magnetic Interference
EN	European Norm
ESA	Electronic Sub-Assembly
EV	Electrical Vehicle
EVC	Electric Vehicle Charger
EVSE	Electric Vehicle Supply Equipment
FCR	Field Call Rate
FMEA	Failure Mode and Effects Analysis
GPRS	General Packet Radio Service
GUI	Graphical User Interface
HMI	Human Machine Interface
HV	High-Voltage
IEC	International Electrical Commission
LED	Light Emitting Diode
LV	Low-Voltage
MSDS	Material Safety Data Sheet
N	Neutral
NEC	National Electrical Code
OCPP	Open Charge Point Protocol
PC	Power Cabinet
PCM	Power Converter Module
PDF	Portable Document Format
PE	Protective Earth
PIN	Personal Identification Number
PLC	Power Line Communication
PP	Proximity Pilot
PPE	Personal Protective Equipment
PPWD	Packaging and Packaging Waste Directive
PRE	Power Research Electronics
PU	Power Unit
PUG	Power Unit Group
PWM	Pulse Width Modulation
RFID	Radio-Frequency Identification
SCCR	Short Circuit Current Rating
SMI	Standard Module Interface

Abbreviation	Definition / Description
SOC	State of Charge
SP	Split Power
TFT	Thin Film Transistor
UL	Underwriters Laboratory
UU	User Unit
WLL	Working load limit

Terminology	Definition / Description
C7.5 / M7.5	(1:4:8) is a lean concrete mix which is used in foundation to provide plain surface and to make a disruption between footing and the ground surface. The compressive strength of the concrete after 28 days is 7.5 N/mm ² .
CCS connector	The CCS plug is used to connect the EVSE to the EV. The CCS connector includes both power lines and communication lines, enabling communication between the EVSE and the EV.
Control pilot	The control pilot, when the EV is connected, takes care of the communication between the EV and the EVSE. The communication between the EV and the EVSE is hard-wired.
Conical spring washer	Conical spring washer is a non-destructive, single use, lock washer which has a curved shape. When the hollow side faces down, the washer adds a load to prevent the bolt / nut to undo itself.
EV coupler	The EV coupler is the installation or means, used to connect the EV to the EVSE. Normally it is a mast with either a contact hood for a pantograph or a mast with an inverted pantograph. When there is no pantograph, the EV coupler has a connection with or without a charging column.
IEC	The International Electrotechnical Commission (IEC) headquartered in Geneva, Switzerland, is the organization that prepares and publishes international Standards for all electrical, electronic and related technologies.
MOT type 1	Crushed gravel stones which provide a load bearing layer for road surfaces, pathways and concrete elements.
NEC	National Electrical Code (NEC) is a set of regularly updated standards for the safe installation of electric wiring in the United States.
tZn	Hot zinc plated
Undisturbed soil	Soil unaltered by filling, removal, or other man-made changes with the exception of agricultural activities.

1. Technical Handbook overview	12
2. Introduction	13
2.1. Notational convention	13
2.2. Warning signs	13
2.3. Identifying signs	14
2.4. Warranty and liability	15
2.5. Use of the system	15
2.5.1. Intended use	15
2.5.2. Unintended use	15
2.5.3. Disposal	15
2.6. Authorized personnel	16
2.6.1. Responsibilities	16
2.6.2. Qualification	16
2.6.3. Acronyms	16
3. Safety information	17
3.1. Safety instructions	17
3.2. Target group	17
3.3. Safety guidelines	18
3.4. Safety warning	18
3.5. General safety notes	18
3.5.1. Important safety instructions	19
3.5.2. Industrial and environment safety measures	20
3.5.3. Personnel safety measures	20
3.6. Onsite installation safety measures	20
3.6.1. Safety of onsite personnel	21
3.6.2. Onsite first aid	21
3.6.3. First response / responder	21
3.7. Safety of the work area	22
3.7.1. Access and escape route	22
3.7.2. Storage of materials and equipment	22
3.8. Safety of civil work	22
3.9. Safety of mechanical works	22
3.9.1. Lifting and hoisting safety	22
3.10. Safety of electrical works	23
3.10.1. Electrical hazards	23
3.11. Lock-out / tag-out	24
3.11.1. Make the system safe	24
3.11.2. Return the system into operation	24
4. Logistic information	25
4.1. Storage and transport	25
4.1.1. Packaging	25
4.1.2. Moving and storage instructions	25
4.1.3. Storage of spare parts	25
4.1.4. Inventory of hazardous material	25
4.2. Handling and safety	26
4.2.1. Goods received notes (GRN)	26
4.2.2. Lifting and hoisting	27
5. Technical specifications	28
5.1. General design	28

5.2.	Electrical specification	28
5.2.1.	Power input requirements	28
5.2.2.	Power output	28
5.2.3.	Connected services	28
5.2.4.	AC Cable	29
5.3.	Cabinet mechanical specification	29
5.4.	Environmental conditions	30
5.5.	Environmental specifications	30
5.6.	Product Compliance	30
5.6.1.	End of Life	30
6.	Product description	31
6.1.	Product overview	31
6.1.1.	Status indicator	32
6.2.	Components and connections overview	33
6.3.	Markings and labels	33
6.3.1.	The type plate	33
7.	Instruction for use	35
7.1.	Contact information	35
	Disclaimer	Fout! Bladwijzer niet gedefinieerd.
7.2.	Moving and storage instructions	35
7.2.1.	Move the Mobile 40kW to the work location	35
7.2.2.	Move the Mobile 40kW to storage	35
7.2.3.	Prepare the Mobile 40kW before use	36
7.2.4.	Use the Mobile 40kW	36
7.2.5.	Store the Mobile 40kW	36
7.3.	Operation of the Mobile 40kW	37
7.3.1.	Connect the AC input	37
7.3.2.	Start the charge session	37
7.3.3.	Stop the charge session	37
7.3.4.	Stop of the charge session - overtemperature	37
7.3.5.	Fan operation	37
7.3.6.	Use of the emergency stop button	37
7.3.7.	How to reset the Mobile 40kW after an emergency stop	38
7.3.8.	How to hard reset the Mobile 40kW	38
7.3.9.	How to soft reset the Mobile 40kW	38
8.	Maintenance information	39
8.1.	Introduction to maintenance	39
8.2.	Maintenance prospect	39
8.2.1.	Preventive maintenance at progressive intervals	39
8.2.2.	Preventive maintenance legal inspection	39
8.2.3.	Mobile 40kW initial maintenance	40
8.2.4.	Mobile 40kW operator maintenance	40
8.3.	Preventive maintenance	40
8.3.1.	Preventive maintenance schedule	40
8.3.2.	Preventive Maintenance Caution	41
8.3.3.	Examine and clean external side	42
8.3.4.	Examine and clean internal side	42
8.3.5.	Examine and test the electrical circuit	45
8.3.6.	Mandatory Checks	46

9. Troubleshooting	47
9.1. Service-line structure	47
9.2. Troubleshooting table	47
9.3. Read faults	47
9.4. Fault descriptions	48
9.5. Event log	49
9.5.1. Abbreviations	49
9.5.2. Explanation of codes	49
9.5.3. Event log codes	50

<i>Figure 1: Mobile 40kW</i>	<i>3</i>
<i>Figure 2: Lifting Graphic</i>	<i>27</i>
<i>Figure 3: Product overview</i>	<i>31</i>
<i>Figure 4: Stop button with status indicator</i>	<i>32</i>
<i>Figure 5: Components and connections overview</i>	<i>33</i>
<i>Figure 6: Type plate - component information</i>	<i>34</i>
<i>Figure 7: Warning label - Risk of electrical shock</i>	<i>34</i>
<i>Figure 8: Remove demister cover</i>	<i>42</i>
<i>Figure 9: Remove demister holder</i>	<i>43</i>
<i>Figure 10: Demister</i>	<i>43</i>
<i>Figure 10: Replace dust filter of air intake</i>	<i>43</i>
<i>Figure 12: Replace dust filter of air exhaust</i>	<i>44</i>
<i>Figure 13: Cooling fan and temperature sensor</i>	<i>44</i>
<i>Figure 14: Examine the power converter</i>	<i>45</i>

1. Technical Handbook overview

The main objective of the Technical Handbook is to give an overview of the product details, specifications, safety information, responsibilities of the personnel, operational and maintenance instructions for the correct operation and maintenance of the product. This Technical Handbook also provides preventive maintenance tasks, spare parts references, information on other required devices, and safety guidelines to support improved operations and service.

This Technical Handbook is an integral part of the product and all the necessary documentation that is required to be kept with the product for easy access to do the safe operation, maintenance and services. All the authorized personnel must be aware of the stipulated instructions in the Technical Handbook before starting any work and every personnel must follow the instructions carefully with caution to avoid any mismanagement.

Siemens is not responsible for any damage caused by ignoring the safety warnings, incorrect follow-up or by failure to follow the correct execution of the instructions outlined in any corresponding chapter in the Technical Handbook. If in doubt, stop the work, do not continue and ask for assistance. However, all the necessary documentation needed for the safe operation and maintenance should be available on request from operators and/or service providers. Not following this Technical Handbook is an infringement of the warranty.

2. Introduction

The Mobile 40kW is built from a standard set of modules and components to convert AC power into DC power as requested by the Electric Vehicle (EV) to charge its battery in compliance with applicable rules and regulations.

This chapter provides information about the notational conventions, safety warnings and signs, warranty and liability, qualification of the personnel, use and disposal, target audience and other related information to familiarize the Mobile 40KW.

2.1. Notational convention

In the blocks below, safety notational conventions (denoted by specific symbols) are illustrated along with their meanings to provide a clear understanding and greater visibility. These blocks require the reader's attention to help avoid dangerous situations and to aid understanding.

	DANGER Utmost attention is required for a possible hazard with a high risk that will result in death or serious physical injury to people if the safety precautions are not met.
---	--

	WARNING Attention is required for a possible hazard with an average risk that can result in death or causes serious physical injury to people if the safety precautions are not met.
--	--

	CAUTION Attention is required for a possible hazard with a low risk that can result in minor to moderate physical injury to people if the safety precautions are not met.
---	---







	NOTICE Attention is required for an additional important message but not hazard related, that can result in damage to equipment or its environment when ignored.
---	--

	REMARK Attention is required for useful additional data to enhance the information or to make the instruction clearer.
---	--

	ENVIRONMENTAL REMARK Attention is required for the environmentally safe disposal of waste, the reuse of materials and the protection of the environment.
---	--



2.2. Warning signs

Warning signs are illustrated below, with each sign's meaning explained.

Symbol	Description
	Risk of Electric Shock / High Voltage Indicates a hazardous situation which, if not avoided, could result in injury due to electrical shock.
	Rotating Parts Indicates a hazardous situation which, if not avoided, could result in injury due to the presence of rotating or moving parts.
	Pinch Hazard Indicates a hazardous situation which, if not avoided, could result in injury involving some body parts to be pinched or crushed.
	Fall Hazard Indicates a hazardous situation which, if not avoided, could result in injury due to unsafe work at height.
	General Indicates a hazardous situation which, if not avoided, could result in damage to the product, connected systems and/or the environment.
	Environmental Damage Indicates a potential hazard to the environment.

2.3. Identifying signs

Identifying signs are illustrated below, with each sign's meaning explained.

Symbol	Description
	Protective Earth Identifying the field wiring equipment grounding terminal (main AC input grounding).
	General Earth Identifying various points within the unit that are bonded to ground.

2.4. Warranty and liability

The Mobile 40kW provided by Siemens are subject to the Siemens General Terms and Conditions of Sale and Siemens Warranty Terms and Conditions, as published on the Siemens website:

<https://www.siemens.com/global/en/general/terms-of-sale/base-terms.html>

<https://www.siemens.com/global/en/general/terms-of-sale/supplemental-terms.html>

2.5. Use of the system

2.5.1. Intended use

The Mobile 40kW is designed to charge an electric vehicle according to the standard for charging electric vehicles (EV) in a safe indoor or outdoor area. The Mobile 40kW is to be installed, commissioned, set into service, maintained and serviced by trained and qualified personnel. The Mobile 40kW is intended to be used during EV battery charge sessions by well trained personnel based on the set qualification and criteria which are stated in [2.5.2. Qualification](#).

2.5.2. Unintended use

This Mobile 40kW is not designed or intended for use in a hazardous area or in a life-threatening environment which could cause serious damage to the health and safety of the personnel and environment. Other use than the intended use can cause loss of life, (serious) injury to personnel and damage to the Mobile 40kW, the connected systems and the environment.



WARNING

This equipment cannot be connected to residential or office power distribution networks.



WARNING

Other use than the intended use can cause loss of life, injury and damage to the product, the connected systems and the environment.

2.5.3. Disposal

Everyone is encouraged to recycle parts and materials to protect the health and safety of personnel and environment.

- Dispose waste and discarded parts in an environmentally safe manner in accordance with federal, state and local government rules and regulations.
- Handle and dispose consumable materials or parts that contain hazardous substances in accordance with environmental safety.
- Follow safety guidelines for handling, operation, maintenance and disposal tasks.
- If in doubt, seek guidance from a supervisor or designated personnel.

2.6. Authorized personnel

The information provided in this document is intended for use by authorized personnel who are involved with the planning, supervision and execution of tasks. These tasks include, but are not limited to the handling, transport and storage, installation, commissioning, operation and maintenance of the Mobile 40kW.

2.6.1. Responsibilities

Work involved with the Mobile 40kW always calls for safe work procedures in the vicinity of electrical installations. Refer to federal, state and local regulations to comply with the required standard and procedures. It is the sole responsibility of the site owner:

- To keep the occupational, health and safety plan up to date and available.
- To allow only authorized personnel to do the work.
- To keep spare and repair parts in accordance with the specifications given in this Technical Handbook.

Only authorized personnel who are qualified in civil, mechanical, electrical, operational, installation, repair and service procedures, and who comply with the specific regulations and requirements set by the authorities, manufacturer, employer and owner of the Mobile 40kW are allowed to work near, on, or within the Mobile 40kW.

2.6.2. Qualification

Qualified and authorized personnel who have read and understood all the relevant instructions are allowed to execute the procedures. Qualifications and authorizations are based on:

- Personnel must be appointed and have accepted the assignment to perform the work. Qualified personnel must have the skills, knowledge, materials, tools and equipment available to install, commission, operate and maintain the Mobile 40kW.
- Qualified and authorized personnel must have completed the relevant Siemens training for the Mobile 40kW.
- Personnel must have completed the specific education for their respective profession.

2.6.3. Acronyms

For an explanation of abbreviations and terminology refer to section [Abbreviations and terminology](#).

3. Safety information

Safety information is meant to contribute to the safety of the personnel and equipment during the installation, commissioning / decommissioning process, operation, maintenance work and services throughout the lifecycle.



NOTICE

RoHS status: following EU Directive 2011/65/EU and Amendment 2015/863/EU.

3.1. Safety instructions

The personnel who operate, maintain, service or repair the installation and the people in the near vicinity of the Mobile 40kW must be informed of the possible hazardous situations. The safety instructions in this section are meant as a guideline and in no way supersede any instruction issued by the federal, state and/or local government authorities, relevant safety regulations or any approved safety standards. Therefore international, national and local government authorities rules and regulations shall always prevail.

Please read carefully and follow the safety instructions before doing any work on the Mobile 40kW, the sub-systems or its components. Make sure to read and be aware of all safety warnings and instructions. Take notice of the safety instructions that are given for the related systems.



NOTICE

If a government / higher authority has more stringent safety instructions than what is mentioned in these safety guidelines, then the instructions from the government / higher authority shall always prevail.

Read the documentation and understand the instructions before starting any work. Follow the instructions carefully. Siemens is not responsible for any damage caused by poor planning, not for incorrect follow-up or execution of the instructions which are given in the related document. If in doubt, do not continue the work and ask for assistance.

Support numbers:

Netherlands, Germany, Austria: +31 88 5016 333

UK & Ireland: +44 (0)20 457 69 498

Belgium: +3 (0)22 585 9987

E-mail: emobility_support.si@siemens.com

3.2. Target group

The Mobile 40kW is designed to charge an electric vehicle according to the standards for charging electric vehicles (EV) in a safe environment. This equipment is intended to be used by qualified, well-trained and Siemens authorized personnel only. Mobile 40kW should not be commissioned in a hazardous area or any area with an existing safety concern or with an environmental concern.

The information given in this document is meant to be used by the authorized personnel who are involved in the planning, supervision and execution of the given tasks. These tasks are not limited to the handling, transport and storage, installation, commissioning / decommissioning, operation and maintenance work because different skills and authorizations are required to execute the task diligently. Work involved with the Mobile 40kW always calls for safe working procedures in the vicinity of the electrical installations. Refer to the federal, state and local

government authorities' guidelines and regulations that apply to the site and installation when performing these tasks.

3.3. Safety guidelines

The safety information is not limited but meant to contribute to the safety of the personnel and equipment during the installation, commissioning / decommissioning, operation, services and maintenance work. Please read carefully and follow the safety instructions before doing any work on the system, the sub-systems or its components. Make sure to read and be aware of the safety guidelines, all the safety signs, warnings, and instructions, and take notice of the safety instructions that are given for the related systems.

3.4. Safety warning

These procedures can lead to hazardous situations if you do not follow the safety precautions and align with the safety instructions and the federal, state and local regulations. Siemens is committed to protect and provide accurate information as complete as possible to warn of hazardous situations when installing the Mobile 40kW and it is the individual's responsibility to adhere to safety measures with the utmost priority.

All the work involved with the Mobile 40kW always calls for safe working procedures in the vicinity of the electrical installations. Personnel are responsible for the supervision and implementation of the instructions given in this guideline and instructions on how to avoid an accident or damage to the equipment when working on the Mobile 40kW or related systems. The possibility of serious injury or damage depends upon various factors:

- The professional skills and authorization of the personnel involved in the planning and the execution of tasks.
- The knowledge of possible hazardous situations where personnel are exposed.
- Execute the tasks carefully and safely.
- Nature of work involved.
- The environmental conditions (e.g. weather, lighting, work area, storm, etc.).

3.5. General safety notes

Reference: ISO45001 Standard.

The general safety is the responsibility of the site owner. The site owner is responsible for creating an Occupational Health and Safety Assessment (OHSA) plan to make sure that before, during and after the installation, commissioning / decommissioning, operation and maintenance work, the safety of the personnel and the property is safe guarded.

The installation site and the EV equipment installed under the responsibility of the site owner shall comply with the manufacture's installation guidelines, however, the federal, state and local government authorities' directives, standards, rules and regulations shall prevail.

3.5.1. Important safety instructions



DANGER

Do not alter the AC power supply. Only allow a qualified electrician to do the electrical work. Improper connection increases the risk of electric shock.

Make sure to align and comply with these instructions:

- Make sure that you save these instructions.
- Follow this manual.
- Comply with all relevant federal, state and local government authorities' laws and regulations.
- Do not use the Mobile 40kW if it is damaged.
- Do not use the Mobile 40kW if any cable is damaged.
- Do not modify the Mobile 40kW without written permission from Siemens. Any change or modification made by the owner without the approval of Siemens can void the warranty policy.
- Only use the Mobile 40kW as intended.
- Only use the Mobile 40kW within the specified technical data.
- The load capacity of the grid must comply with the technical data of the Mobile 40kW.
- Do not touch the inner parts of the Mobile 40kW during, or shortly after the operation as its circuits contain capacitors that can hold a dangerous charge for some time after shutdown. Waiting for a period of at least 5 minutes is recommended.
- Be safe and compliant. Wear personal protective equipment (PPE) as required by the federal, state and local laws, NEC and NFPA70E rules and regulations. Other safety regulations: Safety shoes S3 SRC ESD (ISO20345:2011 & ISO 12568:2010), work clothing / pants (EN1149-5, EN 13034-6, EN ISO 11611 (Class 1 or higher), EN ISO 11612 (A1 A2 B1 C1 E2 F1), IEC 61482-2), high visibility jacket or vest (EN ISO20471) and Electrical protection gloves 1000V (IEC 60903, IEC 61482-1-2 class 2 and ASTM F2675 / F2675M).
- It is recommended to wear electric resistance shoes with mechanical protection of nose and sole during maintenance.
- It is recommended to wear rubber gloves during maintenance if it is unknown if the circuits are completely unenergized.
- Do not operate the Mobile 40kW without the protective devices installed.
- Make sure that the Mobile 40kW is correctly installed. Incorrect installation can void the warranty policy.
- Make sure water cannot enter the product. Do not open the door of the Mobile 40kW when it's raining or with water in the vicinity that may enter accidentally.
- It is recommended to wear an ESD-grounded wrist strap during maintenance on printed circuit boards (PCB) only.
- Do not open the door of the Mobile 40kW during operation.
- Do not use the Mobile 40kW close to (within a distance of 6 meters) an outdoor motor fuel dispensing device.
- Do not install nor use Mobile 40kW products in areas near or exposed to hazardous elements such as fire, explosive material, or chemical hazards.
- Non-authorized personnel are not allowed to perform service and maintenance tasks.
- Non-authorized personnel are not allowed to access to keys of the cabinets. Only qualified Siemens authorized service provider's personnel can access the internal enclosure of the Mobile 40kW by using a key.
- The Mobile 40kW and all the related metal accessories must be connected with an equipment grounding conductor to reduce the risk of electric shock. The Mobile 40kW must be connected to an ACD (Automated Coupler Device) that is properly installed and must be grounded in accordance with all the safety regulations.

3.5.2. Industrial and environment safety measures

	<p>NOTICE These safety notes are site owner’s responsibilities, but mandatory rules and regulations of federal, state and local authorities must be complied.</p>
---	---

- Always keep the work area clean, accessible and well ventilated.
- Remove any spills to prevent slippery floors.
- Dispose of waste and discarded parts in an environmentally safe manner in accordance with the manufacturer's instructions and federal, state and local authorities’ regulations.
- Keep noise emission levels as low as reasonably possible.
- Do not remove the safety guarding if not strictly required for the work and do not reach beyond any guards.
- Use personal protective equipment (PPE) as required by the laws and regulations of local and federal jurisdictions.

3.5.3. Personnel safety measures

	<p>NOTICE These safety notes are site owner’s responsibilities, but mandatory rules and regulations of federal, state and local authorities must be complied.</p>
---	---

Safety is the collective responsibility of every individual. Therefore, a basic safety precaution is required to be implemented by every personnel who are qualified and trained to work on sites:

- Use, maintain and store the personal protection equipment (PPE) as indicated.

3.6. Onsite installation safety measures

The site owner has a few responsibilities which are listed below.

- It is the site owner’s responsibility to make sure that the collective safety measures as well as the personal protective measures and procedures are in place to be adhered.
- It is the responsibility of the site owner to facilitate valid logistic transport, and handling equipment and procedures for the safe handling, transport, and storage of the system parts when requested.

The customer can instruct a safety professional to create safety and health plan before the installation activities begin.

3.6.1. Safety of onsite personnel

	<p>WARNING The use of personal protective equipment (PPE) does not mean ignoring normal safety precautions. The best protection against serious personal injury is care and alignment with safety instructions.</p>
---	--

Safety precautions are taken to avoid accidents to protect the personnel on site and environment. Therefore, always use applicable Personal Protective Equipment (PPE) when performing the work on the Mobile 40kW. PPE is meant to protect health and well-being of the staff who are performing the specific task in a hazardous environment. The incorrect use or lack of maintenance of PPE can result in serious injury to the staff. When the work is in a potentially hazardous situation, do the work with two staff members, one person should be in command (supervisor) while the other person performs the task.

3.6.2. Onsite first aid

	<p>NOTICE These safety notes are site owner’s responsibilities, but mandatory rules and regulations of federal, state and local authorities must be complied.</p>
---	--

The first aid kit should be kept clean and stored in an appropriate and easily accessible location. The materials have a shelf life which is limited and indicated by an expiry date.

3.6.3. First response / responder

The first responder is responsible for their own safety. At a calamity, the Mobile 40kW poses a risk of electrical shock. If a fire is present, first make sure that the electrical power is switched off. For handheld fire extinguishers, only use an extinguisher classification which is dedicated to putting out electrical fires.

	<p>DANGER Risk of electrocution or arc-flashes. Do not use water to extinguish an electrical fire. Water is a natural conductor and will cause electrical shock. An electrical shock can result in serious injury or death by electrocution.</p>
---	---

	<p>NOTICE These safety notes are site owner’s responsibilities, but mandatory rules and regulations of federal, state and local authorities must be complied.</p>
---	--

3.7. Safety of the work area

3.7.1. Access and escape route

Access to the operating area, maintenance area and the escape routes should be kept clear of obstacles, snow and ice at all times. Access to systems and components must be available from suitable places which are accessible from the escape routes.

3.7.2. Storage of materials and equipment

Materials and equipment shall be stored indoors, in a well-ventilated and dry area free from direct radiation by heat or sunlight. For consumable materials, refer to [4.1. Storage and Transport](#). All hazardous materials should be stored in an appropriate area according to the manufacturer's instructions.

3.8. Safety of civil work

Only authorized personnel, who are familiar with the civil work procedures and tasks, shall complete civil work. These personnel shall follow the specific regulations, and the requirements set by the federal, state and local government authorities, manufacturers, employers, and owners of the Mobile 40kW. Civil work is project specific due to the actual site situation or specific restrictions. Therefore, the design of the foundation can be different, and Siemens Project Engineering can provide guidelines if required.

3.9. Safety of mechanical works

Only authorized persons who are familiar with the mechanical installation, repair and service procedures, and who follow the specific regulations, and the requirements set by the federal, state and local government authorities, manufacturers, employers and owners of the Mobile 40kW are allowed to do the mechanical work.

3.9.1. Lifting and hoisting safety



WARNING

Equipment can be heavy, and weight depends upon the size. Use only certified lifting equipment and procedures and please refer to [4. Logistic Information](#). Failure to do so can lead to serious injuries and death.

- Make sure that the weather and the work conditions are suitable for an outdoor lifting operation. Mind overhead power lines!
- Do a visual inspection of the lifting equipment and the related maintenance logbook.
- Make sure the lifting equipment is valid, free of any signs of wear and damage. Lifting equipment that has signs of damage or serious corrosion is unsafe to perform the task.
- Work area should not be blocked by any object. Access to the area should remain free.
- Determine the weight and the center of gravity of the part that will be lifted.
- Comply with the safe working limit and the safe load limit of the lifting equipment.
- Use the appropriate lifting equipment to attach to the parts.
- Lift the parts by the instructions of the designated personnel who supervises the lifting operation.
- Lifting must be done according to the instructions stated in section [4.2.2 Lifting and hoisting](#).

3.10. Safety of electrical works

Only authorized personnel who are familiar with the electrical installation, repair and service procedures, who comply with the specific regulations and requirements set by the federal, state and local government authorities, manufacturers, employers and owners of the Mobile 40kW are allowed to do the electrical work. Electric shock or arc flash can cause personal injuries and equipment damage. Many accidents cause serious electrical shock or serious burns. Fatal shocks are often caused by low, medium and high voltage systems. But even non-fatal electrical shock causes serious injury to persons by e.g. falls from height or arc flashes.

Line of defense

- Never work on electrical installations that are energized!
- Verify with verified measuring equipment (voltage probe) that the electrical installation is unenergized.
- Use valid, sufficiently rated, insulated tools and regular inspection of the protective earth connections for general condition, contact resistance and signs of corrosion.
- Don't take safety risks while performing a task and if there are any safety hazards, stop the work immediately.



WARNING

Make sure that it is safe to work on the electrical system. Energized electrical systems are hazardous and can cause electrical shock or arc flashes. Electrical shock or arc flashes can cause serious injury to personnel when not avoided.

- Make sure the work area is made safe.
- Understand and know the construction and circuits of the electrical equipment. Only authorized or trained personnel shall work on Mobile 40kW.
- Make sure the tools, materials and equipment are calibrated, valid and suitable for the work (e.g. insulated and rated for 1000V).
- The primary power circuits, especially the incoming AC-Terminals can have a very high short circuit current capacity. Use appropriate measuring equipment in these places. No handheld Multimeter is allowed on the primary power circuits. Use a 2-probe voltage tester instead.
- Identify the possible (feedback) energy sources that can cause a hazard.
- Lock out the Mobile 40KW and the related equipment.
- Measure the voltage with a double pole measuring device in conformity with IEC61243-3.
- Make sure the reading is 0 Volt to prove that the system is safe to work on.
- At any time, if the work becomes more hazardous than anticipated, stop and take the required safety precautions and don't take safety risks.

3.10.1. Electrical hazards

- The Mobile 40kW contains conductors that have hazardous electrical voltages.
- The grid connection terminals located at the main circuit breaker have hazardous voltages, even if all circuit breakers are switched off. The local disconnect or unplugging of the AC plug will render this harmless.

3.11. Lock-out / tag-out

This procedure states the minimum requirements for the lock-out of the energy sources (electrical power, etc.) that can cause injury to the personnel. If safety instructions are available from federal, state and local government authorities / higher authority shall prevail.

	<p>WARNING Make sure that it is safe to work on the electrical system. Energized electrical systems are hazardous and can cause electrical shock or arc flashes. Electrical shock or arc flashes can cause serious injury to personnel when not avoided.</p>
---	--

3.11.1. Make the system safe

- Look up the log file and scan for anomalies. If in doubt, contact Siemens Support. Refer to the section [9.5. Event log](#).
- Inform the installation responsible / designated person that a lock-out of the Mobile 40kW (or a part of the supply system) is necessary. Use and wear proper PPE.
- After approval, shutdown the system by the usual stop procedure, see [7.3.3. Stop the charge session](#).
- Make sure no electric vehicle can be connected to DC-Couplers during the service intervention, attach a warning sign; "Do not operate the system - Work in progress".
- At each remote control station and each local control station, attach a warning sign: "Do not operate the system - Work in progress".
- Set the applicable switches / disconnectors to the OFF position and make them safe with a dedicated lock-out device (e.g. personal padlock).
- For the electrical circuits, wait at least for 5 minutes to allow the capacitors to discharge before doing any work.
- For spring loaded components, release the spring tension or apply another safety measure.
- Measure the lock-out condition to confirm that the power sources are set to OFF and the capacitors have discharged so they cannot cause any hazardous situations.

3.11.2. Return the system into operation

- Remove all tools, materials and equipment from the work area.
- Install and secure any protective sheets that were removed earlier.
- Make sure the Mobile 40kW and the work area are safe and clean.
- Make sure the safety related provisions are fit for use.
- Remove the locks and tags.

Inform the responsible / designated person for installation that the task is completed and the Mobile 40kW is ready to get energized.

- Set the applicable switches / disconnectors to the ON position.
- Be aware of possible arc-flashes and return the Mobile 40kW into operation for test purposes.
- Wait for the status indicator to become green (continuously) to show that the Mobile 40kW is ready.
- Test the emergency stop function.
- Do a test session with an EV connected and test the stop function.
- When the test is successfully completed, return the system to service.

4. Logistic information

The following logistic information is meant to contribute to the process of the safe handling, transport and storage of the Mobile 40kW or the related spare parts and equipment. The transport of the Mobile 40kW also includes the hoisting and lifting tasks.

4.1. Storage and transport

This section provides information related to the process of transport and storage of the Mobile 40kW. The personnel who are involved in the process of the handling, transport and storage, as well as the people in the near vicinity of the Mobile 40kW must be informed of possible hazardous situations. The instructions in this document are meant as a guideline and in no way supersede any instruction issued by the federal, state and local government authorities or higher authority or any safety regulatory standard.

4.1.1. Packaging

The Mobile 40kW has standard packaging which is suitable for land-based enclosed or tarped transport and indoor storage. The Mobile 40kW is placed in a wooden crate which is fixed onto the pallet. In special cases, air-freight compliant packaging may be used. Two products are placed on a single pallet.

The total measurement of the package is 800 mm x 500 mm x 500 mm (WxDxH).

The total weight of the packaging, including the product, is 124 kg.

4.1.2. Moving and storage instructions

Rapid changes in the temperature can cause condensation. All equipment shall be stored in a conditioned warehouse to avoid any condensation. The packaging is designed for indoor storage only.

Description	Specification
Packaging	Original packaging, free of damage and contamination
Protection	From radiation from heaters, and direct sunlight (UV)
Environment	Indoor, dry and well ventilated
Minimum temperature	-25°C
Maximum temperature	+50°C
Relative humidity	Between 5% and 95%, no condensation allowed
Rate of temp. change	0.5°C/min

4.1.3. Storage of spare parts

Spare parts are labelled and packaged for indoor storage. Outdoor storage is prohibited. Spare parts should be visually inspected periodically and if found to be damaged, should be replaced and must not be used.

4.1.4. Inventory of hazardous material

The Mobile 40kW complies with the RoHS Directive for the restriction of hazardous substances in electrical and electronic equipment.

4.2. Handling and safety



CAUTION

Handle with care. Prevent sudden shocks and dropping. Rough handling can cause injury to persons and will cause (serious) damage to the equipment.

Refer the [Safety Information](#) stated in this Technical Handbook to get more detailed information on various safety procedures.

4.2.1. Goods received notes (GRN)

Receipt of goods

- It is the responsibility of the transporter / shipment company to make sure the shipment arrives in an undamaged state.
- Inspect the shipment for missing parts and physical damage as soon as the shipment arrives. If discrepancies are seen, report immediately to the carrier or shipping company and Siemens. For future reference, make clear photographs and include them in the damage report.
- In case of missing or damaged parts, new or repaired parts should be made available before connection to the grid and commissioning of the Mobile 40kW.
- Leave the transport tools and the original packaging in place as long as possible to protect the parts against ambient conditions and physical damage.
- If the packaging is opened for inspection upon arrival, reinstall the packaging in its original state to protect the shipment against ambient conditions and possible damage during handling, transport and storage.

Upon receipt of the Mobile 40kW, the related parts and equipment to make sure that:

- The packaging is clean and free of physical damage.
- The parts are correctly identified (labelled) and free of physical damage.
- The shipment is complete in accordance with the supplied packing list.
- The preservation materials and packaging are valid for the intended storage period and location.
- The parts are stored correctly.

4.2.2. Lifting and hoisting

Refer to the [Safety Information](#) stated in this Technical Handbook for detailed safety information. The following points provide general guidelines:

- Note the maximum load of the equipment and the associated accessories.
 - Only use the equipment and its accessories for the purposes for which they are intended.
 - Always use the prescribed safety accessories: helmets, shoes and gloves.
 - Ensure the safety of those nearby; cordon off the area and put out warning signs.
 - Test and approve self-designed accessories before use.
 - Make sure in advance that the hoisting equipment is fit to use; report shortcomings or doubts about this to the supervisor.
 - Work only with approved and undamaged accessories.
 - Ensure a stable and flat base.
 - Hazard identification and risk assessment are an integral part of planning a lift.
 - All persons involved in planning/performing lifting and maintaining lifting equipment shall be trained and competent for their role. Refresher training and periodic assessment are necessary to assure competence.
 - All lifting devices and equipment shall be visually examined before use.
-
- Lifting of the Mobile 40kW can be done by using forklift with the following steps:
 - Inset the fork fully into the pallet opening.
 - Lift the fork with pallet jack.
 - Transfer the unit (Mobile 40kW) wherever it intends to move.
 - Bring down the fork and place the Mobile 40kW on the stable surface.
 - Remove fork.



Figure 2: Lifting Graphic

	<p>WARNING Equipment can be heavy, and the weight depends upon the size. Use only certified lifting equipment, procedures, and read the lifting equipment manuals to perform the task. Failure to do so can lead to serious injuries and death.</p>
---	--

The handling and lifting equipment shall be rated and certified for the work. Note that certain equipment requires a trained and certified operator. The site owner, installation partner or their representative shall provide a validated hoisting and lifting plan wherever applicable. Refer the [Technical Specifications](#) for dimensions and weights.

However, the installer / site owner does not have to provide a hoisting plan as long as their method is in line with the standard way of lifting. In any case if specific solutions are needed, Siemens Project Engineering can be asked to review practices and methods to provide assistance.

5. Technical specifications

This section provides technical specifications as well as the compliance details of the Mobile 40kW and information on torque values.

5.1. General design

Description	Specification
Human Machine Interface	Plug and charge. The product can have optional external Emergency stop, Stop button and RGB status indicator.
Ingress Protection	IP 54
Mechanical Impact Protection	IK10. (Note: IK08 for air inlet and outlet)
Corrosion class	C4H

5.2. Electrical specification

5.2.1. Power input requirements

This equipment contains earth leakage current protection devices (ground fault interrupters) based on recommended standards.

Description	Specification
Input connections	3P + PE Note: Phase balanced load, no neutral wire required.
Input power, full load	43 kVA.
Input power, idle	280 VA.
Input AC line voltage range	400VAC± 10%
Input AC line frequency	50 Hz
Input current limit values	16 A / 32 A / 63 A
Input AC phase current, max.	63 A
Power factor	>0.9
Peak efficiency	>94% (>95% above 14kW)
Total Harmonic Distortion	I< 5%.
Dielectric withstand	3000 Vac (Test voltage between internal live parts and accessible parts 3000 Vac is not applicable to all parts). Dielectric strength according IEC61439 for grounded equipment.
SCCR	10 kA.

5.2.2. Power output

Description	Specification
Output connections	DC+, DC-, PE, CP
Output DC voltage range	100 - 1000 Vdc
Rated DC output power	40 kW
Rated DC output current	0 - 66.67 A

5.2.3. Connected services

Description	Specification
Cellular	WAN, 4G Modem, LAN

Network type	4G LTE/ 3G UMTS/ 2G GPRS/ Ethernet
Back office	OCPP Based Backoffice, e.g. Chargesight

5.2.4. AC Cable

	<p>CAUTION Every cable must be correctly labelled according to its function with watertight labels. The labels must be clearly visible during and after installation of the cables.</p>
---	--

Description	Specification
AC cable	Purpose: AC Main power, 400 V, 63 A, 3P, and PE Type: H07RN-F-4G Supplier: Eupen Core section: 4 x 16 mm ²

5.3. Cabinet mechanical specification

Description	Specification
Material	Powder Coated Steel, C4H
Color	Cabinet: RAL 7022 (Grey) Carriage RAL 1023 (yellow)
External Dimensions (± 5 mm):	
Depth	500 mm
Width	500 mm
Height	800 mm
Weight	127 kg & with Packaging 164 kg

5.4. Environmental conditions

Description	Specification
Ambient temperature range	-20° C to 40° C (derating above 36° C, 38.5kW @ 40° C) Full output power
Relative humidity	Between 5% and 95%, no condensation allowed
Operating Altitude	Up to 2000 m above sea level

5.5. Environmental specifications

Description	Specification
Environment	This equipment is designed for indoor/outdoor use.
Operating noise level [dB(A) @ m]	<60 dB(A) @ 1 m.

5.6. Product Compliance

This product complies with the essential requirements of the following EU Directives for CE marking:

- 2014/53/EU (Radio Equipment Directive)
- 2022/30/EU (Commission Delegated Regulation Supplementing Directive 2014/53/EU)
- 2011/65/EU (RoHS Directive)

Further information about the conformity to these Directives and the relevant harmonized standards applied can be found in the full EU Declaration of Conformity.

5.6.1. End of Life

This product is marked with the crossed-out wheeled bin symbol in accordance with the EU Directive 2012/19/EU on Waste Electrical and Electronic Equipment (WEEE). This symbol indicates that this product must be collected separately from other waste at the end of its life to allow for proper treatment and recycling. The product shall be handed over to an appropriate collection point for recycling of electrical and electronic equipment. Proper disposal helps prevent potential negative consequences for the environment and health and promotes the reuse, recycling and/or recovery of the materials of which the equipment is composed. Incorrect disposal of the product by the user will result in the application of the penalties provided for in current legislation. In addition, product packaging and non-electrical/electronic equipment must be disposed of in accordance with applicable local regulations.

6. Product description

This section outlines the physical product description of the Mobile 40kW.

The Mobile 40kW consists in an all-in-one concept, power converters and user interface. The Mobile 40kW is the perfect solution for a secure and semi-rapid domestic or public charging system. It is an EV (Electric Vehicle) Charging Station.

The Mobile 40kW uses a DC current flow to charge the battery of EVs that support CCS protocol. It has a status indicator which is part of the stop button.

It is possible to have a software API for integration and management. Ask for further information via the e-mail address: emobility_support.si@siemens.com.

6.1. Product overview

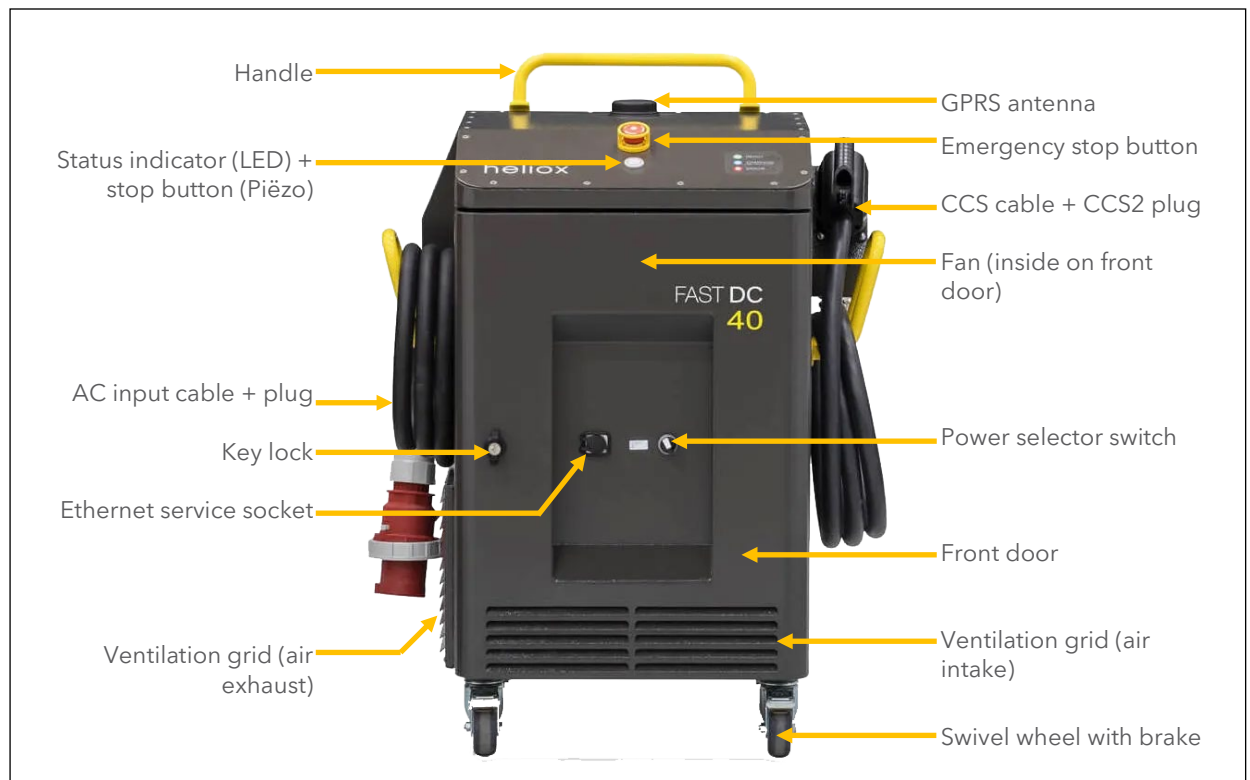

Figure 3: Product overview

6.1.1. Status indicator

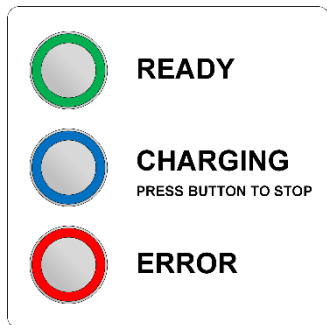

Figure 4: Stop button with status indicator

READY: The Mobile 40kW is in standby and available.

CHARGING: The Mobile 40kW charges an EV.
Press the button to abort the charging session.

ERROR
The Mobile 40kW has a fault and is not ready to use

The following table provides details on status Indicator.

Color	Duration [s]	Description
None	-	The Mobile 40kW is in an unavailable state.
Green, blinking	60	The Mobile 40kW is in the initialization phase.
Green, continuous on	continuous	The Mobile 40kW is in standby and awaits an EV to connect.
Blue, blinking	20	The Mobile 40kW starts or stops a charging cycle.
Blue, steady	continuous	The Mobile 40kW charges an EV.
Red, steady	continuous	The Mobile 40kW has a fault and is not ready to use.

6.2. Components and connections overview

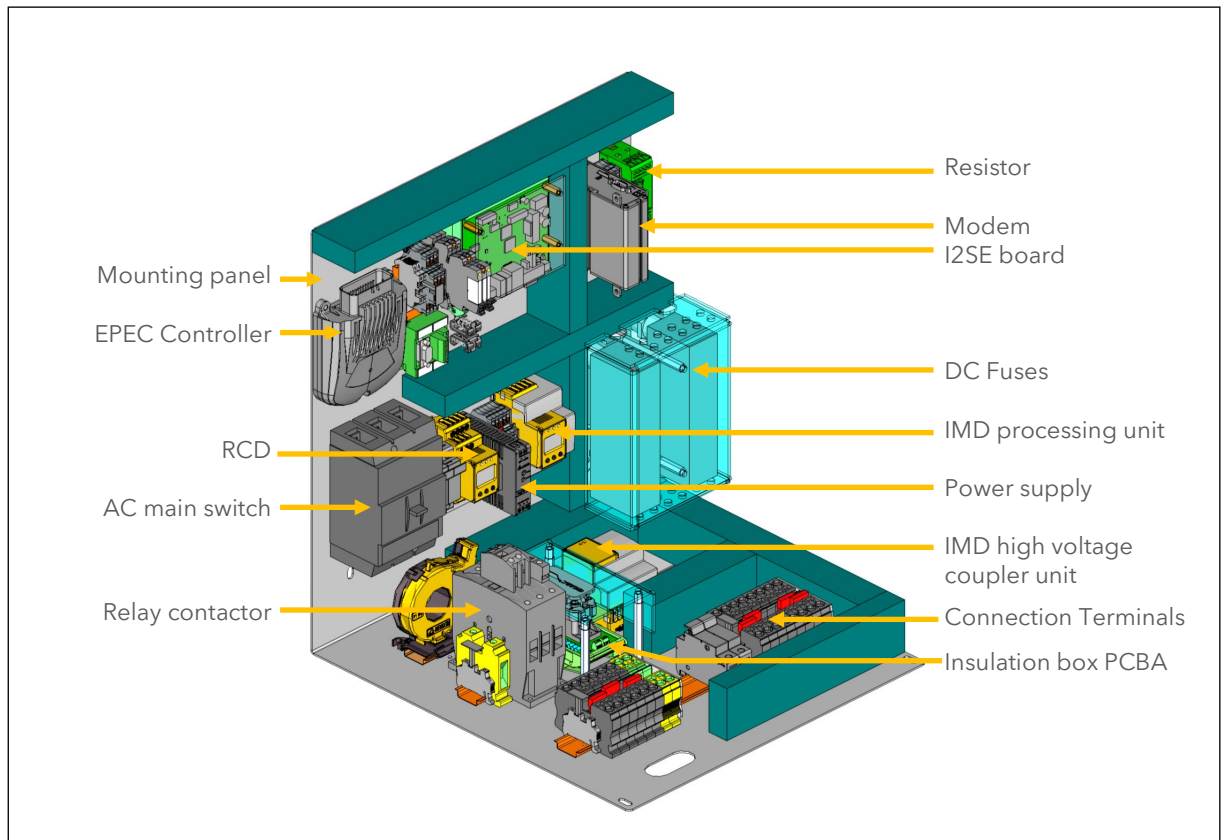

Figure 5: Components and connections overview

6.3. Markings and labels

6.3.1. The type plate

The type plate gives the identification and the electrical details of the Mobile 40kW. See the example below for the image and fields of the type plate. The type plate of different products varies to some degree, but it generally contains the information shown below.







SIEMENS				
Name		Mobile 40kW		
Article Number Art.-Nr.		8EM2000-.....-.....		
Date Datum	SN	HW. Ver		
Input Eingang		AC: 400V, 3P+PE @ 50 Hz, ≤ 16 A / 32 A / 63 A		
Output Ausgang		DC: 100 – 1000Vdc, 0 - 66.67A @ 40°C, 40kW		
Interface Schnittstelle		CCS2		
IP	Temp.	IP54	-25°C to +45°C (derating may apply)	
		     		
Siemens eMobility Charging B.V., BIC 1, 5657 BX Eindhoven, The Netherlands Made in Slovakia				

Figure 6: Type plate - component information

The fields of type plate show the cabinet specific details:

- Name of product
- Article Number
- Date & Serial number & Hardware version
- Input AC parameter values
- Input DC parameter values
- Interface - Cable type
- IP rating & Temperature range
- CE logo and sign
- Address of the manufacturer

The warning labels

The electrical safety label is attached at different locations to warn for the risk of electrocution by a high voltage.



Risk of electrical shock

To reduce the possibility of electrical shock, set the power switches in the OFF position and lock-out/tag-out the Mobile kW before you do any work. Always take the necessary safety measures to allow for a safe work area.

Figure 7: Warning label - Risk of electrical shock

7. Instruction for use

This section outlines the operational instruction of the Siemens Electric Vehicle Supply Equipment (Mobile 40kW) to support the understanding of the product operation in order to familiarize the instruction for use.

7.1. Contact information

Siemens eMobility Charging B.V.

BIC 1, 5657 BX Eindhoven,
The Netherlands.

Support numbers:

Netherlands, Germany, Austria: +31 88 5016 333

UK & Ireland: +44 (0)20 457 69 498

Belgium: +3 (0)22 585 9987

E-mail: emobility_support.si@siemens.com

Web address: <https://www.siemens.com/de/de/produkte/energie/emobility.html>

7.2. Moving and storage instructions

7.2.1. Move the Mobile 40kW to the work location

1. Put the Mobile 40kW on a stable, horizontal surface in a dry location with sufficient circulation of clean air for cooling purposes.
2. Make sure that the cables do not pose a threat to persons who pass by.
3. Take the required safety measures to protect the cables and persons. If necessary, use cable protection slabs.

7.2.2. Move the Mobile 40kW to storage

1. Make sure that the charge session is completed.
2. Stop the charge session. Refer to section Stop the charging process (electric vehicle) in this manual.
3. Make sure that the CCS cable and the CCS plug are dry, clean and free from damage and corrosion.
4. Wait until the ventilation has stopped.
5. Disconnect the AC connector from the wall socket.
6. Make sure that the AC cable and connector are dry, clean and free from damage and corrosion.
7. Put the AC cable with the connector on the cable rack of the Mobile 40kW. Make sure that the connector pins face downward.
8. Move the Mobile 40kW to a safe storage location free from risk of damage.

7.2.3. Prepare the Mobile 40kW before use

1. Verify that the power level switch is set to level according to grid connection.
2. Examine the Mobile 40kW, the components and the wall socket for contamination and signs of damage.



WARNING

Do not put the Mobile 40kW into service in case of contamination or damage.

3. Put the Mobile 40kW in a safe and convenient location for charging the EV.
4. Make sure that the charge site is safe. If necessary, use warning signs or temporary fences.
5. Unwind the AC cable fully.
6. Connect the AC plug to an appropriate wall socket.
7. Wait until the green LED indicator comes on.

7.2.4. Use the Mobile 40kW

1. Verify that the power level switch is set to the level according to the grid connection.
2. Unwind the CCS cable fully.
3. Connect the CCS plug to the socket of the EV.
4. Wait until the blue LED indicator blinks. Communication is in progress.
5. Wait until the charge session starts. Make sure that the blue LED indicator is on constantly.

7.2.5. Store the Mobile 40kW



WARNING

Store the Mobile 40kW in an environment that complies with the technical specifications. Refer to chapter [5. Technical specifications](#).

Please refer to [5.4. Environmental conditions](#) for permissible relative humidity and altitude values applicable to Mobile 40kW.

7.3. Operation of the Mobile 40kW

7.3.1. Connect the AC input



NOTICE

The AC input of the Mobile 40kW is a delta configuration.

1. Connect the plug of the AC input cable to the mains socket.
2. Select the input current (16A / 32A / no limit) with the power limit switch.
3. Wait until the LED ring turns constant green. The LED ring shows the status of the Mobile 40kW. Refer to [6.1.1 Status indicator](#).

7.3.2. Start the charge session

1. Park the vehicle at the indicated location near the Mobile 40kW.
2. Activate the vehicle brake.
3. Unwind the CCS cable fully.
4. Connect the CCS plug to the electric vehicle. When correctly connected, the blue LED flashes for 20 seconds and stays on.

7.3.3. Stop the charge session



NOTICE

The built-in fan in the Mobile 40kW cabinet operates for an additional minute after the charging process stops.

1. Press the stop button on the Mobile 40kW to stop the charging process.
The blue LED turns off.
 2. Disconnect the CCS plug from the electric vehicle.
 3. Return the CCS plug to its original position on the Mobile 40kW.
- When all operations are completed, the green LED stays on.

7.3.4. Stop of the charge session - overtemperature

If the Mobile 40kW detects that the internal temperature is too high, it will trigger a stop of the charging process. The Mobile 40kW will disable until the temperature is at an acceptable level. The fan keeps spinning after the stop of the charging process. Refer to [7.3.5 Fan operation](#)

7.3.5. Fan operation

The Mobile 40kW has a built-in fan at the front (refer to [6.1. Product overview](#)) of the cabinet. After the charging process stops, the fan operates for an additional minute. This enables additional cooling of the Mobile 40kW.

When the emergency button is pressed, the fan stops spinning immediately to prevent any risks.

7.3.6. Use of the emergency stop button

1. Locate the emergency button. Refer to [6.1. Product overview](#).
2. Push the emergency stop button to shut down the Mobile 40kW in an emergency situation.
3. Pressing the emergency stop button trips the safety breakers and requires a reset of the button to continue use.

7.3.7. How to reset the Mobile 40kW after an emergency stop

1. Locate the emergency button. Refer to [6.1. Product overview](#).
2. Turn the emergency stop button clockwise to reset the emergency stop button.

7.3.8. How to hard reset the Mobile 40kW

1. If the CCS plug is connected to the vehicle, disconnect the CCS plug.
2. Disconnect the AC cable from the mains.
3. Wait until all the LED ring does not show any light. Refer to [6.1.1 Status indicator](#).
4. Connect the AC cable to the mains.
The Mobile 40kW begins the start up phase.



CAUTION

If the Mobile 40kW does not start up, there is a serious fault. Make a soft reset. Refer to [7.3.9 How to soft reset the Mobile 40kW](#).



NOTICE

The LED ring shows the status of the Mobile 40kW. Refer to [7.3.9 How to soft reset the Mobile 40kW](#).

7.3.9. How to soft reset the Mobile 40kW

- Do this procedure if the LED ring of the Mobile 40kW shows that a fault has been present for more than 1 minute. Refer to [6.1.1 Status indicator](#).
 - If the Mobile 40kW does not start up after a soft reset, make a hard reset. Refer to [7.3.8 How to hard reset the Mobile 40kW](#).
1. Make sure that the AC input cable is connected to the mains power supply.
 2. Use the emergency stop button. Refer to [7.3.6 Use of the emergency stop button](#).
 3. Release the emergency stop button, by turning it clockwise.
The Mobile 40kW should begin the start up phase.



CAUTION

If the Mobile 40kW does not start up, there is a serious fault. The Mobile 40kW needs a service. Refer to [9.1 Service-line structure](#).



NOTICE

The LED ring shows the status of the Mobile 40kW. Refer to [7.3.8 How to hard reset the Mobile 40kW](#).

8. Maintenance information

8.1. Introduction to maintenance

This section outlines the planning of maintenance, the related operational, and preventive maintenance tasks. The typical preventive maintenance tasks are defined as visual inspections, technical cleaning and changing the filter elements, etc. when applicable. Further tasks include doing the operational tests, adjustments of the systems, and the components. The operational and the preventive maintenance tasks are done with the parts and the tools which are normally available in the standard toolset of an electrical maintenance engineer.



DANGER

Isolate the Mobile 40kW before you do maintenance.

- **Disconnect the CCS plug from the EV.**
- **Disconnect the Mobile 40kW from the main power supply.**

Wait five minutes after these disconnections before you begin the maintenance.



NOTICE

The Mobile 40kW is cooled with fan air. Minimize dust around the Mobile 40kW to avoid damage to the cooling system.

8.2. Maintenance prospect

Maintenance is a prospect to keep the Mobile 40kW and the related components in a safe, technically reliable, and economically viable condition. Well planned executed maintenance is carried out to keep the equipment operational without failure to avoid downtime and economic loss where a company shows its reliability, efficiency, maintenance, and performance management. Maintenance is a well-balanced mixture of knowledge, doing the right thing at the right time, maintenance processes, analysis and assessment, preventive maintenance and condition-based maintenance either human assessment or sensor assisted.

8.2.1. Preventive maintenance at progressive intervals

Preventive maintenance at progressive intervals means to execute the scheduled preventive maintenance tasks of the nearest interval during a scheduled or an unscheduled maintenance activity or a repair of the Mobile 40kW. The maintenance intervals inform when which tasks must be done at the least. However, there can be unscheduled events in between these intervals. If the Mobile 40kW or a related component is out of service for whatever reason, it is cost-efficient to do the upcoming preventive maintenance tasks as well, but make sure the given tasks are done at least once per interval.

8.2.2. Preventive maintenance legal inspection

It can happen that the given maintenance interval does not meet the maintenance requirements from the authority for legally demanded tasks, e.g. the insulation measurements. In these events, the maintenance interval as demanded by the legal authorities prevails. For the detailed information and the instructions, please refer to the statutory and regulatory standards and directives issued by the federal, state and local government authorities and other legal documents.

8.2.3. Mobile 40kW initial maintenance

The aim of the Mobile 40kW initial maintenance is to make sure that the Mobile 40kW and the related components, after a major repair or an overhaul, operate within the specified parameters. These initial maintenance procedures are also done when the Mobile 40kW or related component returns to service after a period of 3 months of standstill.

8.2.4. Mobile 40kW operator maintenance

The operator maintenance is limited to daily inspections and maintenance tasks that do not require skilled electrical personnel who are allowed to operate and maintain the electrical installation. Typical operator tasks are visual inspection and cleaning of the external side as well as cleaning and installing the new air filter elements.

8.3. Preventive maintenance

Planning and the maintenance schedules are intervals that are based on the calendar time or calculated from the operating hours. The maintenance is done at least one time per given interval or more frequently as required by the operational profile. The maintenance intervals are meant as a guideline. Always consider the operational profile to align with the manufacturer's instructions.

8.3.1. Preventive maintenance schedule

The preventive maintenance schedule is based on calendar time. Note that if the outcome of a task to examine is not satisfactory, an on-condition task needs to be done to restore the Mobile 40kW in a serviceable condition. The maintenance intervals are:

- Annually means: Do the task at least 1x per year.
- 5 years means: Do the task at least 1x per 5 years.
- 10 years means: Do the task at least 1x per 10 years (overhaul).

Annual maintenance is performed based on the "Warranty Policy and SLA", however:

- If the Mobile 40kW doesn't reach the annual minimum charge cycle, then the annual maintenance can be postponed to attain the annual minimum charge cycle.
- If the Mobile 40kW exceeds the annual maximum charge cycle, then additional maintenance can be performed based on an additional maintenance fee.

The letters in the maintenance schedule table identifies the lowest skill set to execute the task. The letters given are:

O (Operator): The owner or a designated service employee of the Mobile 40kW.

A (Authorized Service): A person who is allowed by education and training to execute the task.

H (Siemens Service): A person from the Siemens service department.

Interval/Task	Half yearly	Yearly
8.3.3. Examine and clean external side		
Task 1 Examine and clean the external side	O	
8.3.4. Examine and clean internal side		
Task 1 Examine and clean the inside of the Mobile 40kW	A	
Task 2 Examine and clean the demister	A	
Task 3 Examine, clean or replace the inlet filter	A	
Task 4 Examine, clean or replace the exhaust filter	A	
Task 5 Examine, clean and test the cooling fan	A	
Task 6 Examine, clean and test the power converters	A	
8.3.5. Examine and test the electrical circuit		
Task 1 Examine the electrical connections	A	
Task 2 Tighten the electrical connections when necessary	A	H
Task 3 Examine the electrical components	A	
8.3.6. Mandatory Checks		
Task 1 Examine external side & rework external side if necessary	A	
Task 2 Examine door seal and lock, clean and grease the seal	A	
Task 3 Test a charge session	A	
Task 4 Test emergency stop button	A	
Task 5 Check the CCS cable	A	

8.3.2. Preventive Maintenance Caution

Following preventive maintenance safety cautions are provided to support the preventive maintenance task in a safe and efficient manner without any harm to the service personnel and the environment or the product.

	<p>CAUTION Do not use any aggressive or chemical cleaning agents. The component is only resistant to water. Aggressive / chemical cleaning agents can cause (serious) damage to the component.</p>
---	---

	<p>CAUTION Do not use a high-pressure jet, any sharp tools or any scouring pads. The high-pressure jet, any sharp tools or the scouring pads will make the surface rough or cause damage to the surface. The rough surfaces will contaminate more quickly and can cause serious damage to the surface.</p>
---	---

8.3.3. Examine and clean external side

The product contains a number of components that are subject to maintenance checks on regular intervals.

Task 1 Examine and clean the external side

The EVSE is made of steel which has a powder coating to prevent the EVSE for deterioration by ambient conditions. To keep the powder coating in a good condition, it is necessary to clean the surface at regular intervals.

- Examine the external side.
- Clean with a dry lintless cloth or microfiber towel.
- If necessary, clean with a damp cloth and non-caustic agent.

8.3.4. Examine and clean internal side

1. Make sure that the AC input cable is disconnected.
2. Unlock the key-lock with the appropriate key. Turn the lever counterclockwise.
3. Open the cabinet.

	<p>CAUTION Avoid serious damage to the Mobile 40kW. Do not operate the Mobile 40kW while the front panel is open. The cooling fan does not cool the device while the front panel is absent.</p>
---	--

4. After maintenance, close the front door.
5. Turn the lever clockwise and lock the key-lock.

Task 1 Examine and clean the inside of the Mobile 40kW

- Check inside of the Mobile 40kW cabinet for anomalies. Make sure there is no condensation inside the cabinet.
- Use an anti-static vacuum cleaner to clean the inside of the Mobile 40kW cabinet from top to bottom.

Task 2 Examine and clean the demister

- Make sure that the front door is open.
- Remove screws ① (8x).
- Remove the cover ②.

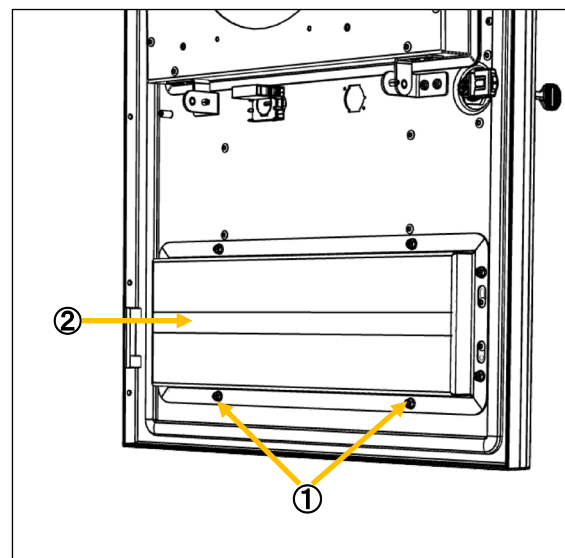

Figure 8: Remove demister cover

- Remove the screws ③ (2x).
- Remove the demister holder ④.

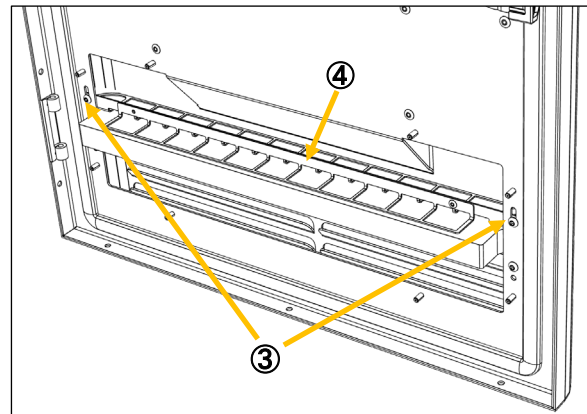

Figure 9: Remove demister holder

- Take out the demister.
- Rinse the demister. Use water.
- Gently squeeze the demister until it does not retain water.
- Place the demister back in the door.
- Tighten the screws.
- Install the cover.

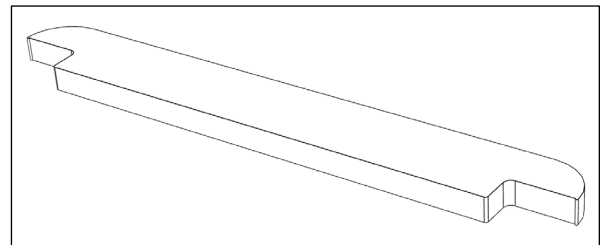

Figure 10: Demister

Task 3 Examine, clean or replace the inlet filter

1. Make sure that the front panel is opened.
2. Loosen the screws ①.
3. Open the frame ② of the fan.
4. Replace the dust filter.
5. Close the frame of the fan.

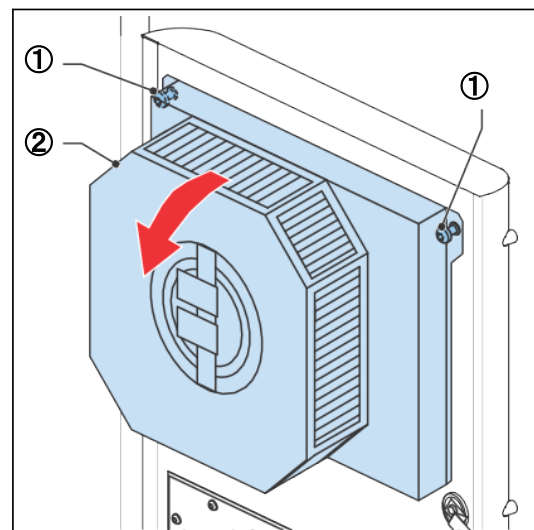



Figure 11: Replace dust filter of air intake

Task 4 Examine, clean or replace the exhaust filter

	<p>NOTICE For the exact location of the air exhaust refer to section 6.1. Product overview.</p>
---	--

- Remove the screws ①.
- Remove the cover ② of the air exhaust.
- Replace the dust filter ③ (HE7119001).
- Install the cover on the air exhaust.

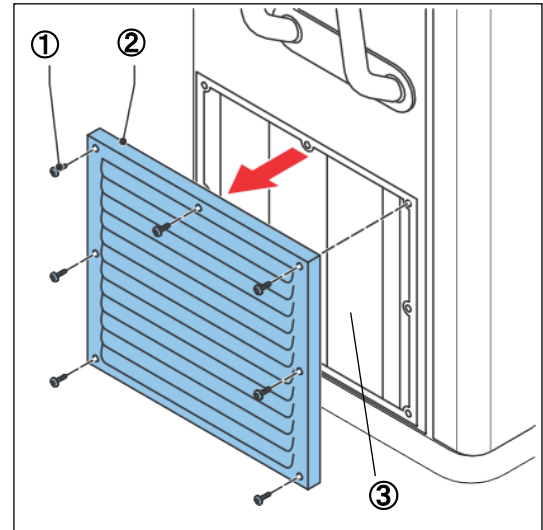

Figure 12: Replace dust filter of air exhaust

Task 5 Examine, clean and test the cooling fan

The cooling fan (3M3) is located in the front panel of the Mobile 40kW.

- Open the front panel of Mobile 40kW.
- Unscrew the ventilator. Refer to [8.3.4. Examine and clean internal side](#) > Task 3 Examine, clean or replace the inlet filter
- Examine the fan (3M3) in the cabinet. Make sure that the fans are working properly.
- Make the fans dust free if necessary.
- Use a hot air gun to heat up the temperature sensor (12B1) to test whether the cooling fan starts.

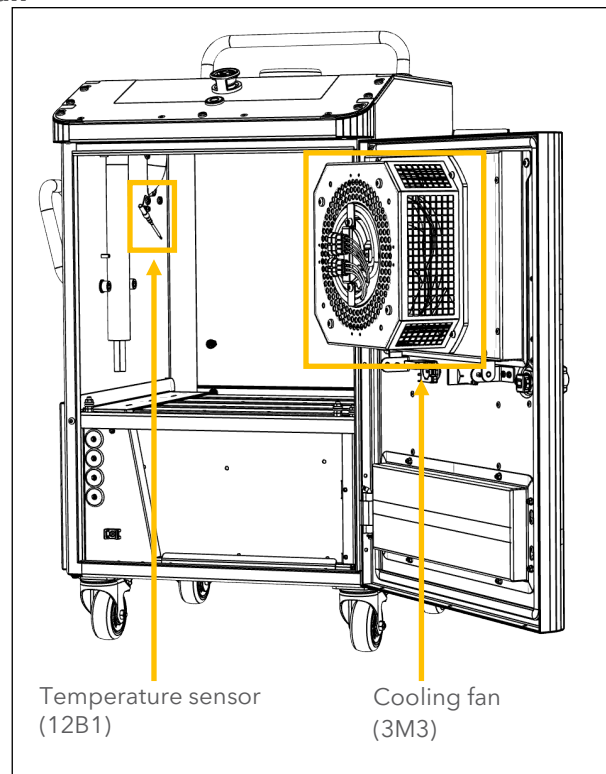

Figure 13: Cooling fan and temperature sensor

Task 6 Examine, clean and test the power converters

- Examine the power converters (4U1, 4U6, 5U1 and 5U6)
 - Check the mounting.
 - Check the connectors behind the power converters.
 - Examine the fans for contamination.

- Clean the fans of the power converters.

- Use a hot air gun to heat up the temperature sensor (12B1) to test whether the cooling fan starts. See [Figure 13](#).

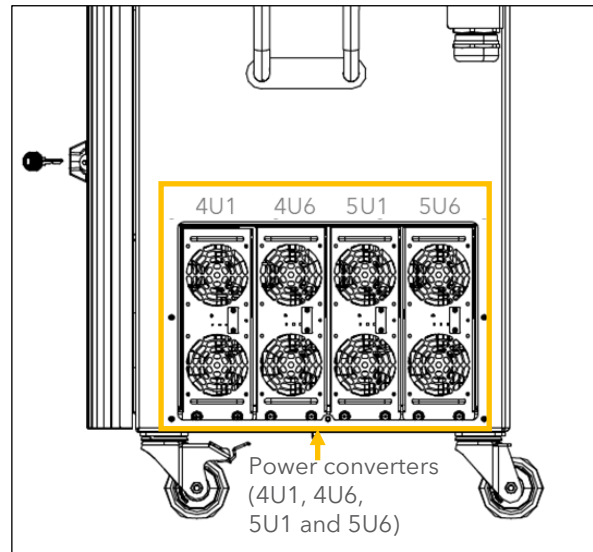

Figure 14: Examine the power converter

8.3.5. Examine and test the electrical circuit

Task 1 Examine the electrical connections

- Check the wires and connections: Connections that have torque marking which are not moved are okay.

Task 2 Tighten the electrical connections when necessary

- Check the tightening torques: To do this:
 - the connections must be loosened,
 - conical washers and spring washers must be replaced,
 - bolts and nuts must be tightened with the correct torque and marked for torque.

However; adjusting the connection is only to be done if:

- the torque marking is shifted,
- the connection shows visual signs of overheating,
- the connection is measured with a temperature measuring device and shown to be hot. If a connection was hot it is not sufficient to be re-torqued.

Task 3 Examine the electrical components

- Examine the electrical components. Check all components for anomalies (discoloration, corrosion and damage).

8.3.6. Mandatory Checks

Task 1 Examine external side & rework external side if necessary

- Examine the external side of the cabinet for corrosion and / or scratches.
- Rework external side if necessary. Contact Siemens if significant corrosion is present.
- Instructions for repairing damaged powder coating.
 1. Use a wire brush to remove the rust, and any loose or flaking coatings from the damaged area.
 2. Use sandpaper to smoothen the surface.
 3. Apply solvent cleaning to remove grease and other contaminant residues.
 4. Once the surface has been cleaned, use a touch-up brush or spray system to apply colour match paint.

Important notes:

- Repainting should be done as soon as possible after cleaning.
- Ensure that the selected touch-up brush or spray system is applicable for your application.
- Ensure that you follow each painting product's technical specifications and operating instructions.

Task 2 Examine door seal and lock, clean and grease the seal

- Examine the door seal.
- Examine the operation of the door lock if needed.
- Clean and grease the seal if necessary. Use acid-free vaseline on the door seal.

Task 3 Test a charge session

- Follow the procedure which is stated in the section [Instructions for use](#) to test the charge session.
An EV is required.

Task 4 Test emergency stop button

Press the emergency button (31S1).

- The LED ring color shall change to red or the colour as defined in the system configuration (Default and recommended setting is red).
- Release the emergency button by rotating it clockwise.
The button automatically returns to the original raised position (Do not pull).
- Make sure that the LED ring colour changes to green or to the colour as defined in the system configuration (Default and recommended setting is green).
- Repeat the same steps if multiple emergency buttons are present for the system.

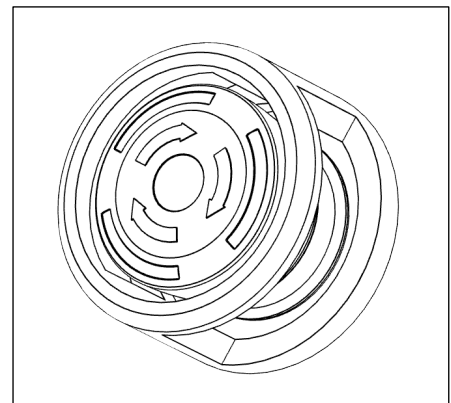

Figure 15: Emergency button

Task 5 Check the CCS cable

- Check the CCS cable for damage caused by dragging it over the ground.
- Wipe gently clean with a dry cloth.

9. Troubleshooting

9.1. Service-line structure

The service-line is structured in such a way that simple faults can be fixed with the help of the 1st line support. Depending on the complexity of the issue, you will be further directed to the specific service department.

Support line	Contact	Action
1st line support	Vehicle Operator	Reset of the Mobile 40kW
2nd line support	Local service company	Physical check, measurements and a hard-reset
3rd line support	Heliox service department	Additional support



NOTICE

A report of every executed service action must be made and subject to Heliox support e-mail address. Refer to section [7.1. Contact information](#). It is important to mention the type number and the serial number of the product in the report.

9.2. Troubleshooting table



NOTICE

Refer to section [6.1.1. Status indicator](#) for the normal functioning of the active LEDs.

Fault	Action
There is no LED active for more than 10 seconds.	Check the mains connection.
The red LED is active.	Use the troubleshooting section of the maintenance manual to identify the fault. Use the service-line structure to contact the correct service department. Refer to 9.1 Service-line structure .



NOTICE

If other problems occur during the operation, use the service-line structure to contact the correct service department. Refer to section [9.1 Service-line structure](#).

9.3. Read faults

A connection to the SECCs must be established to get a complete overview of the possible Mobile 40kW faults.

1. Connect a laptop to the Ethernet service socket with an Ethernet cable. Use only a CAT5e Ethernet cable or higher.
2. Connect to the IP address:
For output-1, go to <http://192.168.1.2>
3. Search for the fault in the fields that are the color red.
4. Use the information in section [9.4 Fault descriptions](#) to solve the problem.

9.4. Fault descriptions

Fault	Trigger	Reference
Mains relay fault	Mains relay feedback contact	Device 2K2.
Initialization fault	Time-out of 40 seconds for initialization. Starts when the EV is connected (STATE B) and is reset at STATE C.	Check the EV-Connection. Cable-section between Mobile 40kW and CCS plug.
Cable check fault	Time out of 3 minutes. Starts when the system is in STATE C and is reset when system is precharging.	Check the EV-Connection. Cable-section between Mobile 40kW and CCS plug
Cable precharge fault	Time-out of 9 seconds for precharging of the Mobile 40kW DC output. Starts when the voltage request > 0 and is reset at EVReadyToChargeState signal from EV	DC voltage of drive (4U1, 4U6, 5U1, and 5U6) does not rise above 60 V DC, does not measure the Mobile 40kW DC voltage properly, or there is a mismatch between requested voltage of EV and provided voltage by Mobile 40kW.
Emergency button	Set at when emergency button is pressed.	Check status of emergency button. Device -2S2.
Short circuit	Cable Status = CABLE_CHECK_FAULT	Check the EV-Connection. Cable-section between Mobile 40kW and CCS plug.
Isolation fault	IMD status = ISOLATION_FAULT, IMD status = ISOLATION_WARNING, IMD failure	Check status of isolation monitor. Device 7U3. Check impedances between main power circuit and PE.
Cabinet temperature fault	Set when cabinet temperature is above 50 °C. Automatically reset when temperature decreases below 40 °C.	Check status of fan -3M3.
Coupler temperature fault	Coupler temperature fault set when above 100 °C. Reset below 80 °C.	Check CCS coupler-plug combination.
General error	Fault that is reset when the cause is removed.	Check web interface for cause.
General malfunction	Fault that requires removal of the cause and a system reset.	Check web interface for cause

9.5. Event log

9.5.1. Abbreviations

The table shows the explanation of the abbreviation used in the event log.

Abbreviation	Description
EEA	EV Mobile 40kW association
ICP	Inrush current protection (used for DC and precharge contactors)
IMD	Insulation monitoring device
OCPP	Open charge point protocol
PWT1_FB	Power-train 1 field bus
SCC	Short circuit check
SEEC	Supply equipment environment controller
SEPC	Supply equipment power converter

9.5.2. Explanation of codes

Event log code

	<p>NOTICE The warning code is only used for diagnose purposes.</p>
--	---

Table: Example of the different items that represent the event log code.

Time and date	Severity	EVENT_LOG	Module ID	Warning code
1970-01-01T00:5 9:22.511Z	3	EVENT_LOG	1	85;0;4;4;1;F8;

Severity code

Table: Explanation of the level of severity.

Level of severity	Description
1	Alarm on
2	Alarm off
3	Warning on
4	Warning off
5	Information
7	Version

9.5.3. Event log codes

Event log code	Severity	Module ID	ErrorWarning Code	Description	Action service engineer
1;EVENT_LOG;1;1	1	IMD1	insulationFault	Insulation fault resistance under setpoint	Check EV / Mobile 40kW insulation resistance
1;EVENT_LOG;1;2	1	IMD1	requestService	Insulation device inresponsive	Check IMD
3;EVENT_LOG;1;85	3	IMD1	insulationWarning	Insulation warning resistance under setpoint	No action
1;EVENT_LOG;2;1	1	SEPC1	CanTimeout	CAN time out	Check canbus 2 (epcc <-> DCM123A)
1;EVENT_LOG;2;2	1	SEPC1	CanVariableOverflow	CAN message receive failure	Check canbus 2 (epcc <-> DCM123A)
1;EVENT_LOG;2;3	1	SEPC1	MissedHeartbeat	Heartbeat message dropped	Check drive online state during charging (green LED on drives)
1;EVENT_LOG;2;4	1	SEPC1	ArbitrationTimeout	Drives failed to identify to software	Check if all drives are functional (orange LED on drives)
1;EVENT_LOG;2;5	1	SEPC1	InresponsiveState	Drives became inresponsive	Check drive online state during charging (green LED on drives)
1;EVENT_LOG;2;6	1	SEPC1	SetpointDifference	Not yet implemented	Not yet implemented
1;EVENT_LOG;2;7	1	SEPC1	ConverterPrimaryOvertemperature	Primary side of converter over temperature	Check fan spinning, check air outtake filter not clogged
1;EVENT_LOG;2;8	1	SEPC1	ConverterSecondaryOvertemperature	Secondary side of converter over temperature	Check fan spinning, check air outtake filter not clogged
1;EVENT_LOG;2;9	1	SEPC1	ConverterAmbientOvertemperature	Ambient side of converter over temperature	Check fan spinning, check air outtake filter not clogged
1;EVENT_LOG;2;10	1	SEPC1	DCVoltageOutOfRange	DC voltage -> 60V before converter activated	Check for possible voltage source
1;EVENT_LOG;2;170	5	SEPC1	internalState	Internal arbitration state (for debugging only)	For debugging on
1;EVENT_LOG;4;1	1	DCCC1	illegalStateChangeFault	No normal state transition	Make log backup reset Mobile 40kW
1;EVENT_LOG;4;2	1	DCCC1	evEmergencyStopCP	EV emergency stop received	Check EV error code

Event log code	Severity	Module ID	ErrorWarning Code	Description	Action service engineer
1;EVENT_LOG;4;3	1	DCCC1	cpLossFault	CP disconnect detected	Check CP path connections
1;EVENT_LOG;4;4	1	DCCC1	readyToChargeTimeOut	Charge session time out, no progression	Check diagnose data why session not progressed
1;EVENT_LOG;4;5	1	DCCC1	Mobile 40kWssionFault	PLC link terminated	Make log backup reset EV
1;EVENT_LOG;4;6	1	DCCC1	couplerStartupVoltage-OutOfRange	DC voltage > 60V before convertor activated	
1;EVENT_LOG;4;7	1	DCCC1	readyToChargeStateSetTooEarly	EV set readyToCharge bit to early	
3;EVENT_LOG;4;85	3	DCCC1	highVoltageDuringDischargeWarning	After stop session DC voltage not dropped <40V on time	
3;EVENT_LOG;4;86	3	DCCC1	readyToChargeStateNotSet	EV readyToCharge bit not set	
3;EVENT_LOG;4;87	3	DCCC1	v2gLimitsNotSet	EV limits not set	
3;EVENT_LOG;4;88	3	DCCC1	communicationTimeout	Communication timeout detected	
3;EVENT_LOG;4;89	3	DCCC1	cableCheckTimeout	cablecheck timeout detected	
3;EVENT_LOG;4;90	3	DCCC1	prechargeTimeout	precharge timeout detected	
3;EVENT_LOG;4;91	3	DCCC1	chargerSetToUnavailable	charger set to unavailable	
1;EVENT_LOG;6;1	1	SCC1	shortCircuitFaultMonitor	Short circuit detected	
1;EVENT_LOG;6;2	1	SCC1	requestServiceMonitor	Short circuit device inresponsive	
1;EVENT_LOG;7;1	1	OCPP1	CanTimeout	CAN time out	
3;EVENT_LOG;7;85	3	OCPP1	CanRXError	CAN message receive failure	
3;EVENT_LOG;7;86	3	OCPP1	CanTXError	CAN message transmit fail	
1;EVENT_LOG;11;1	1	V2G1	CanTimeout	CAN time out	
3;EVENT_LOG;11;85	3	V2G1	CanRXError	CAN message receive failure	
3;EVENT_LOG;11;86	3	V2G1	CanTXError	CAN message transmit failure	
3;EVENT_LOG;11;87	3	V2G1	EVErrorCode	Received	
1;EVENT_LOG;13;1	1	EEA1	CanTimeout	CAN time out	
3;EVENT_LOG;13;85	3	EEA1	CanRXError	CAN message receive failure	
3;EVENT_LOG;13;86	3	EEA1	CanTXError	CAN message transmit failure	
3;EVENT_LOG;13;87	3	EEA1	CriticalAttenuation	PLC attenuation critical low	

Event log code	Severity	Module ID	ErrorWarning Code	Description	Action service engineer
1;EVENT_LOG;14;1	1	ICP1	ContactorPositiveFault	Contactor inresponsive	
1;EVENT_LOG;14;2	1	ICP1	ContactorNegativeFault	Contactor unresponsive	Check contactor
1;EVENT_LOG;14;3	1	ICP1	ContactorPrechargeFault	Contactor unresponsive	Check contactor
3;EVENT_LOG;14;85	3	ICP1	InvalidStateRequest	No normal state transition	Make log backup reset Mobile 40kW
3;EVENT_LOG;14;86	3	ICP1	OpenedWithCurrent	Contactor opened with current	No action
3;EVENT_LOG;14;85	1	PWT1_FB	InvalidStateRequest	No normal state transition	Make log backup reset Mobile 40kW
3;EVENT_LOG;14;86	1	Ac-Board	Actuator not responding in time	Contactor actuator contact not in line with sense contact (contactor took too long to respond to request)	Check contactor operation
1;EVENT_LOG;127;4	1	General	CabinetTemperature	Control cabinet temperature out of range	Check fan spinning, check air intake/ outtake filter not clogged
1;EVENT_LOG;127;5	1	General	EmergencyButtonPress	Emergency button pressed	check emergency button
1;EVENT_LOG;127;8	1	General	Mobile 40kW1CurrentNotPlausible	Not yet implemented	Make log backup reset EV
1;EVENT_LOG;127;10	1	General	PLCnotOK	PLC malfunction	Make log backup reset Mobile 40kW

More information

<https://www.siemens.com/emobility>

Siemens eMobility Charging B.V.
BIC 1, 5657 BX Eindhoven,
The Netherlands

